



MODEL NUMBER: **GRCMAFA100BKEW**

FREE 3 YEAR WARRANTY REGISTRATION
3 ANS DE GARANTIE, INSCRIPTION GRATUITE
REGISTRO DE GARANTÍA DE 3 AÑOS GRATIS
KOSTENLOSE REGISTRIERUNG 3 JAHRE GARANTIE
三年免费保固
www.AccessoryPower.com/warranty



For troubleshooting information, please visit the link below:
Pour des informations de dépannage, merci de visiter le lien ci-dessous :
Para obtener información sobre la solución de problemas, visite:
Um Informationen zur Fehlerbehebung zu erhalten, klicken Sie bitte den folgenden Link:

有关疑难解答信息，请点击下面的链接：

www.AccessoryPower.com/FAQ

USA GEAR®

**ACTION
MOUNTS
SERIES™**

A MOUNT FOR EVERY SITUATION
For action and tripod mount cameras

UN SUPPORT POUR TOUTE SITUATION
Pour caméras d'action et supports trépieds



Zip Mount



Chest Strap



Helmet Mount



Head Strap



**Handlebar
Mount**



**Large
Adhesive
Mount**



**Flat
Adhesive
Mount**



Wrist Strap



Suction Mount



www.accessorypower.com/actionmounts

USA GEAR®

FLAT ADHESIVE MOUNT

4

Package contents L'emballage contient Contenidos del paquete Packungsinhalt 包装内容

Mount
Support
Soporte
Halterung
支架

Adhesive base
Surface adhésive
Base Autoadhesiva
Klebender Sockel
粘胶底座



Right angle adapter
Adaptateur à angle droit
Adaptador para Angulo Derecho
Rechtwinkliger Adapter
直角连接器

Tripod screw adapter
Adaptateur trépied à vis
Tornillo adaptador para trípode
Stativ Schraubadapter
三角架螺丝座连接器

5

Product diagram
Schéma du produit
Diagrama de product
Produktabbildung
产品图

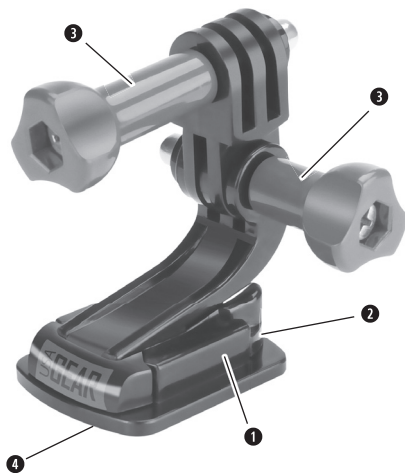

6

1
Mount slot
Fente du support
Ranura para el Soporte
Halteungsschlitz
支架卡槽

2
Mount release
Démontage du support
Extraction del Soporte
Halteverschluss
支架解锁

3
Mount screw
Vis du support
Tornillo del Soporte
Halteungsschraube
支架螺栓

4
Adhesive pad
Patins adhésifs
Almohadilla Autoadhesiva
Klebepad
粘胶垫

7

Operating instructions
Mode d'emploi
Instrucciones de Operación
Bedienungsanleitung
操作说明

Connect mount
Fixer le support
Conecte el Soporte
Halter anbringen
连接支架

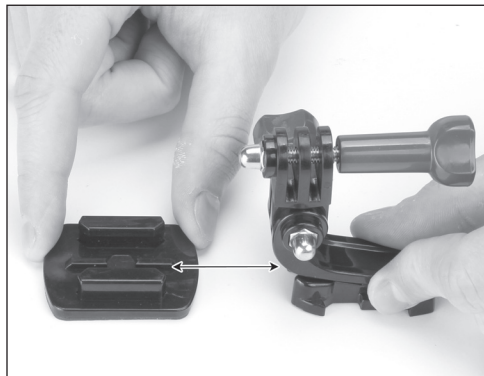

8

Insert the mount into the mount slot until you hear the buckle click
Insérez le support dans la fente jusqu'à entendre le clic de la boucle
Inserte el soporte en la ranura hasta escuchar que la hebilla haga clic
Schieben Sie den Halter in die dafür vorgesehene Öffnung, bis die Schnalle einrastet.

插入支架到支架卡槽直到你听到扣紧的声音

9

Attach mount base
Fixer le support pour caméra
Coloque la base del soporte
Schließen Sie den Sockel am Halter an
连接支架底座

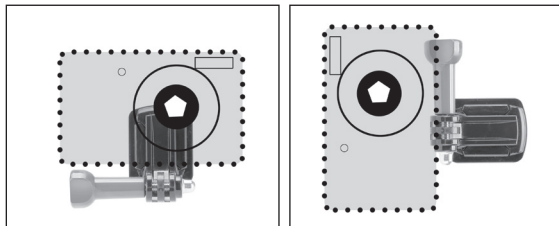

Place the adhesive base in your desired position. Make sure the mount slot faces the correct position for your desired camera angle

Positionnez la surface adhésive dans la position désirée. Assurez-vous que les fentes du support correspondent à votre angle de caméra souhaité

Coloque la base autoadhesiva en la posición deseada. Asegure que la cara del soporte este en la posición correcta para obtener el ángulo de cámara deseado

Befestigen Sie den klebenden Sockel an der gewünschten Stelle. Für den gewünschten Kamerawinkel, vergewissern Sie sich, dass die Halterung in die richtige Richtung zeigt

请将粘胶底座放在所需的位置·确保支架卡槽面向您的相机想要的角度的正确位置

10



Make sure the mounting surface is smooth, dry and clean of debris. Peel back the adhesive backing. Press and hold the mount down for 60 seconds for a secure connection

Assurez-vous que la surface de montage soit lisse, propre et sans débris. Retirez le support adhésif. Appuyez et maintenez le support pendant 60 secondes pour une connexion sécurisée

Asegure que la superficie esté lisa, seca y limpia de impurezas. Quite el film adhesivo. Presione y mantenga hacia abajo por 60 segundos hasta que la conexión sea segura.

Vergewissern Sie sich, dass die Oberfläche sauber und glatt ist. Entfernen Sie die Klebefolie. Für eine sichere Verbindung, halten Sie die Halterung für 60 Sekunden nach unten gedrückt.

确保安装表面平滑·干燥和干净·撕开粘胶底布·按住支架向下60秒确保粘贴安全牢固。

11

Attach action mount camera
Fixer le support caméra
Coloque el soporte de la cámara
Befestigen Sie die Action Mount Kamera
连接装好相机的活动支架

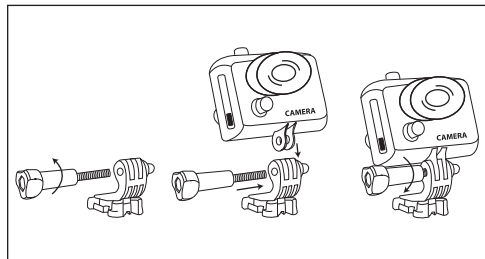

12

Remove the mount screw and insert the camera housing into the mount.
Reinsert the mount screw

Retirez la vis du support et insérez l'adaptateur pour la vis de trépied dans le support. Remettez la vis du support. Insérez l'adaptateur trépied à vis dans la prise de trépied de l'appareil photo et serrez.

Remueva el tornillo del soporte e inserte la carcasa de la cámara en el soporte. Vuelva a colocar el tornillo del soporte

Lösen Sie die Schraube und befestigen Sie das Kameragehäuse in der Halterung. Schrauben Sie die Halterungsschraube wieder fest.

移开支架的螺栓，将相机连接器插入支架，然后重新插入支架螺栓

13

Attach tripod mount camera

Fixer le support trépied de la caméra

Coloque el soporte de trípode para la cámara

Schließen Sie die Stativhalterung an

把相机安装在三角架连接器上

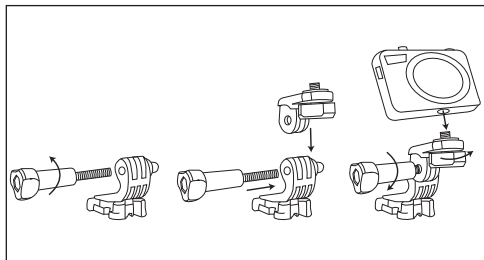

Remove the mount screw and insert the tripod screw adapter into the mount. Reinsert the mount screw. Insert the tripod screw into your camera's tripod socket and tighten

Retirez la vis de support et insérez l'adaptateur pour la vis de trépied sur le support. Remettez la vis du support. Insérez l'adaptateur pour la vis de trépied sur la prise de trépied de l'appareil photo et serrez

Remueva el tornillo del soporte e inserte el tornillo adaptador para trípode en el soporte. Reinserte el tornillo del soporte. Inserte el tornillo del trípode en el agujero de su cámara y apriete

Lösen Sie die Schraube und befestigen Sie das Kameragehäuse in der Halterung. Schrauben Sie die Halterungsschraube wieder fest. Drehen Sie dann die Stativschraube in das Stativgewinde Ihrer Kamera.

取出支架螺栓插入三角架螺丝连接器到支架，再装上支架螺杆，把三角架螺杆插入相机三角架接口拧紧。

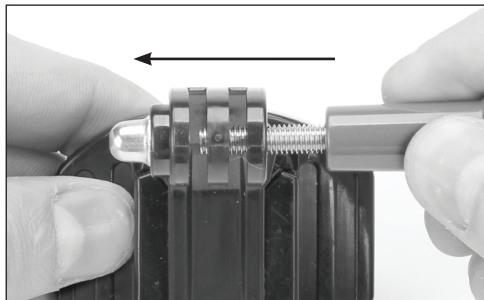

For a secure thread connection, press the nut outwards with the screw and then tighten

Pour une fixation sécurisée, positionnez l'écrou sur la vis, vissez et bien serrez

Para asegurarse una correcta instalacion, presione la tuerca con el tornillo hacia el exterior y ajuste

Für einen sicheren Gewindeanschluss, drücken Sie die Mutter mit der Schraube nach außen und ziehen Sie sie dann fest

为了螺丝连接安全·按住底座向外的螺帽然后拧紧螺栓

16

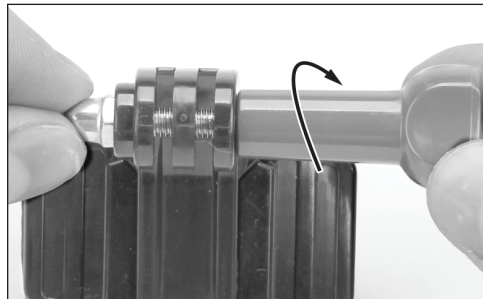
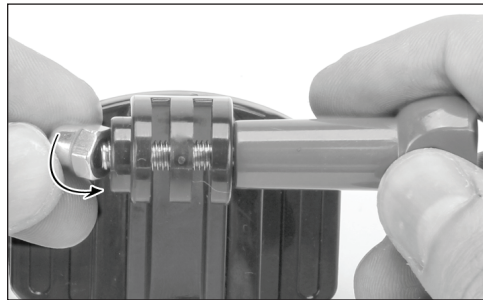

17

Right angle adapter
Adaptateur à angle droit
Adaptador para Angulo Derecho
Rechtwinkliger Adapter
直角连接器

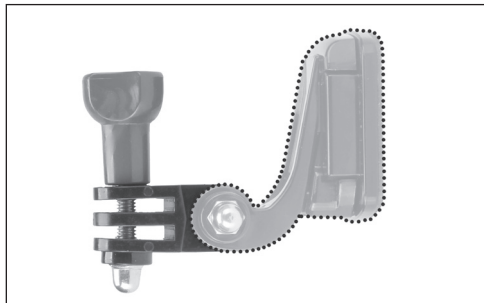

For a right angle shooting position, use the right angle adapter between the mount and camera

Pour une position prise-de-vue à angle droit, utilisez l'adaptateur à angle droit entre le support et la caméra

Para una correcta posición de disparo desde el ángulo derecho, utilice el adaptador de ángulo derecho entre el soporte y la cámara

Für eine rechtwinklige Position beim Fotografieren, benutzen Sie den rechtwinkligen Adapter zwischen Ihrer Kamera und der Halterung

为了一个理想的拍摄位置，请使用支架和相机之间的直角连接器

18

Adjust
Régler
Ajuste
Anpassen
调校



Position the camera to your desired angle and make sure all screws are secure
Placez la caméra dans l'angle souhaité et assurez-vous que toutes les vis soient sécurisées

Posicione la cámara en el ángulo deseado y asegúrese que todos los tornillos estén en la posición correcta

Richten Sie die Kamera aus und vergewissern Sie sich, dass alle Schrauben angezogen sind

放置相机在您想要角度的位置并确保所有的螺杆操作是安全的

19

Product specifications
Spécifications du produit
Especificaciones del producto
Produktspezifikationen
产品规格

Technical specifications:
Dimensions fully assembled: 3 x 2.81 x 2.5 inches
Weight: 2.08 ounces

Détails techniques :
Dimensions fully assembled : 7.62 x 7.13 x 6.35 cm
Weight : 59 gr



Trademark information Informations sur la marque déposée

GoPro

GoPRO, HERO, the GOPRO logo, and the GoPro Be A Hero logo are trademarks or registered trademarks of GoPro, Inc.

Works with GoPro's Hero camera

Toshiba Camileo X-Sports

Camileo is a registered trademark of Toshiba America Information Systems, Inc. Toshiba and the Toshiba logo are registered trademarks of Toshiba Corporation.

Coleman Xtreme Action Camera

Coleman and the Coleman logo is a trademark or registered trademark of The Coleman Company, Inc.

Drift HD Ghost

Drift, the HD Ghost logo, and the Drift Logo are trademarks or registered trademarks of Drift Innovation

ION AIR PRO

The ion logo is a registered trademark of World Wide Licenses Limited.

AIR PRO and its respective logo is a trademark or registered trademark of World Wide Licenses Limited in the United States and other countries

JVC ADIXXION

ADIXXION is a trademark or registered trademark of JVC Kenwood Corporation of Japan JVC is a registered trademark of JVC Kenwood Corporation of Japan

KODAK PIXPRO

Kodak and the Kodak logo are registered trademarks of Eastman Kodak Company

Midland XTC

Midland and the Midland logo are registered trademarks of Midland Radio Corporation

Polaroid XS

Polaroid, Polaroid Classic Border Logo, Polaroid Color Spectrum are registered trademarks of PLR IP Holdings, LLC.

SONY HDR

Sony and HDR are trademarks or registered trademarks of Sony Corporation

Swann Freestyle

Swann and the Swann logo are registered trademarks of Swann Communications Ltd.

Veho Muvi

Veho and Muvi are trademarks or registered trademarks of Veho UK Ltd.

Pentax

Pentax is a registered trademark of HOYA Corporation

Panasonic

Panasonic is the registered trademark of Panasonic Corporation

Canon

Canon is the registered trademark or trademark of Canon Inc. and/or other members on the Canon Group

Fujifilm

Fujifilm is a registered trademark or trademark of Fujifilm Corporation

Nikon

Nikon is a registered trademark or trademark of Nikon Corporation

Olympus

Olympus is a registered trademark or trademark of Olympus Corporation

Samsung

Samsung is a trademark of Samsung Electronics Co.



[YouTube.com/AccessoryPower](https://www.youtube.com/AccessoryPower)



[Facebook.com/AccessoryPower](https://www.facebook.com/AccessoryPower)



[Twitter.com/AccessoryPower](https://www.twitter.com/AccessoryPower)



ACCESSORY POWER®

© 2014 AP Global, Inc. All rights reserved. Accessory Power, the Accessory Power logo, USA GEAR, USA GEAR Action Mount Series, the USA GEAR logo, and other Accessory Power marks and logos are either registered trademarks or trademarks of AP Global, Inc. in the United States and/or other countries. All other trademarks are the property of their respective owners.

Manufactured in China. Designed in California.

© 2014 AP Global, Inc. Tous droits réservés. Accessory Power, le logo Accessory Power, USA GEAR, USA GEAR Action Mount Series, le logo USA GEAR, et les autres marques et logos d'Accessory Power sont soit des marques déposées soit des marques de AP Global, Inc. aux États-Unis et/ou dans d'autres pays. Toutes les autres marques sont la propriété de leurs propriétaires respectifs.

Fabriqué en Chine. Conçu en Californie.



**WARNING! THIS PRODUCT IS NOT LIFE SAVING EQUIPMENT.
AVERTISSEMENT! CE PRODUIT N'EST PAS UN EQUIPEMENT DE SAUVETAGE.**