

USER GUIDE • GUIDE DE L'UTILISATEUR



ENHANCE®

REGISTER NOW



ENREGISTRER

This product comes with a 1 year limited warranty.

Register this product within 30 days of sale to activate a complimentary 2 year warranty extension and receive free advanced technical support. Learn more and register now.

Ce produit a une garantie limitée de 1 an.

Enregistrez ce produit dans les 30 jours suivant son achat pour activer l'extension de garantie de 2 ans et bénéficier de notre service après-vente gratuit. Pour en savoir plus, enregistrez ce produit dès à présent.

[ENHANCEgaming.com/warranty](https://www.enhancegaming.com/warranty)

BECOME A VIP



Free Product Giveaways
Exclusive Discounts
Sneak Peek at New Products
And More VIP Perks!

AccessoryPower.com/VIPclub

LIKE US ON FACEBOOK



Join Our Community
and Stay Up-To-Date
with News & Promotions

Facebook.com/AccessoryPower

IN LESS THAN 30 SECONDS



Need help with this product?
Besoin d'assistance sur ce produit?
¿Necesita ayuda con este producto?
Benötigen Sie Hilfe bei diesem Produkt?
Hai bisogno di aiuto per questo prodotto?
购买的产品，是否需要提供协助？

AccessoryPower.com/support

Product diagram
Schéma du produit
Diagrama de producto
Producktabbildung
Schema del prodotto
产品图

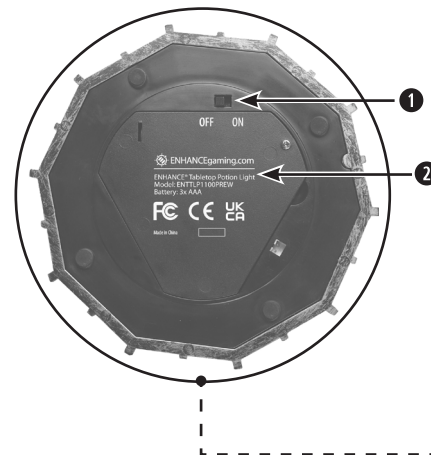

EN

- 1 Power switch
- 2 Battery cover

FR

- 1 Interrupteur
- 2 Couvercle de la batterie

ES

- 1 Interruptor de alimentación
- 2 Tapa de la batería

DE

- 1 Stromschalter
- 2 Batterieabdeckung

IT

- 1 Energia
- 2 Coperchio della batteria

ZH

- 1 力量
- 2 電池殼

Operating instructions



Unscrew the battery door (screwdriver not included).

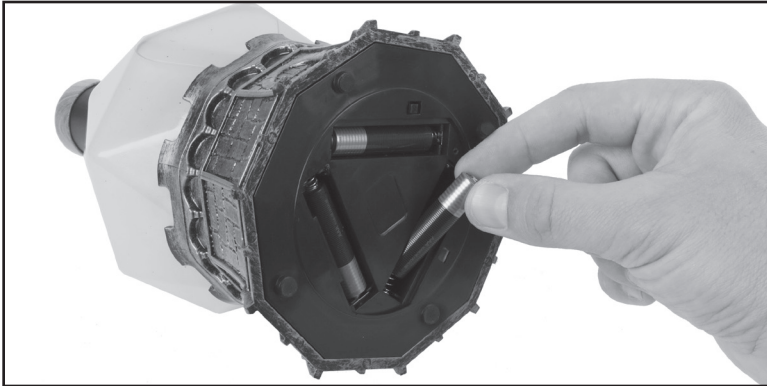

Insert 3x AAA batteries (not included).

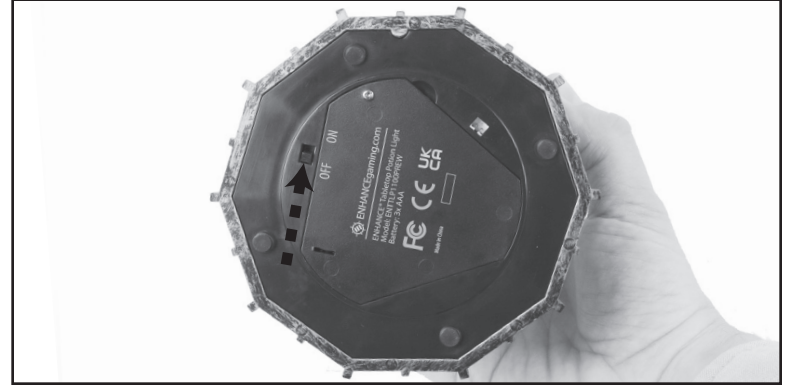

Replace the battery cover and move the power switch to the ON position.

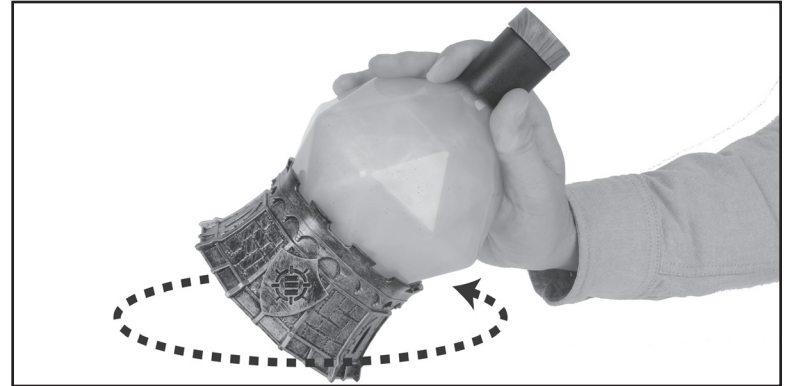

NOTE: If the potion is not swirling. Turn off the light, give it a gentle shake and then turn back on.

Instructions d'utilisation



Dévissez la porte de la batterie (tournevis non inclus).

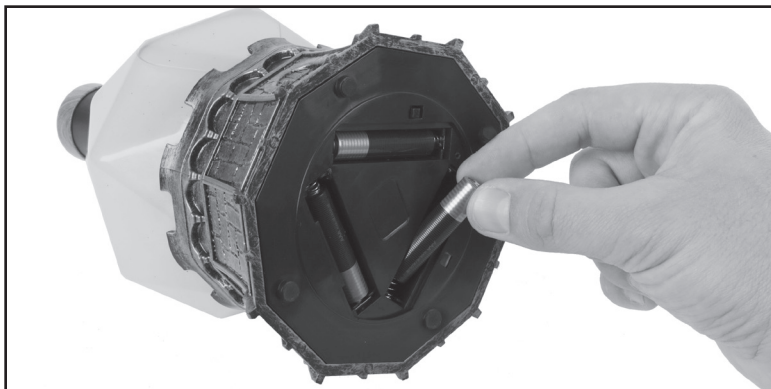

Insérez 3 piles AAA (non incluses).

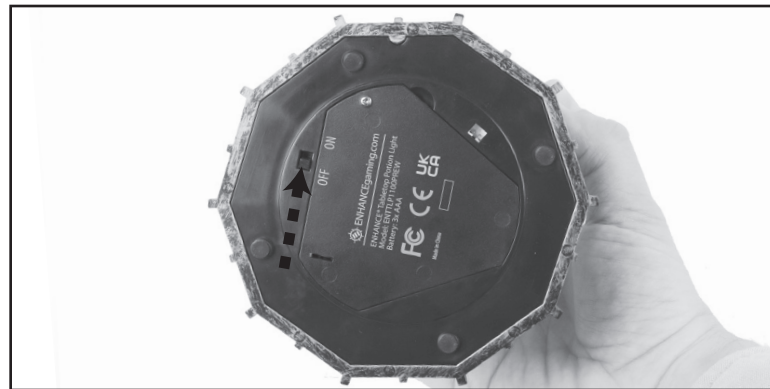

Remplacez le couvercle de la batterie et placez l'interrupteur d'alimentation sur la position ON.

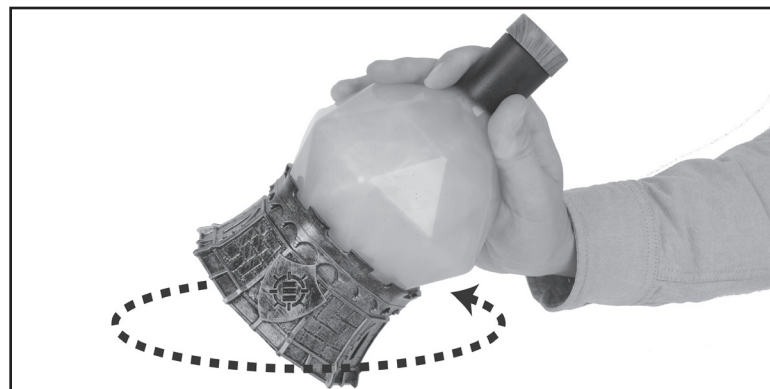

REMARQUE : si la potion ne tourbillonne pas. Éteignez la lumière, secouez-la doucement, puis rallumez-la.

Instrucciones de operación



Desenrosque la puerta de la batería (destornillador no incluido).

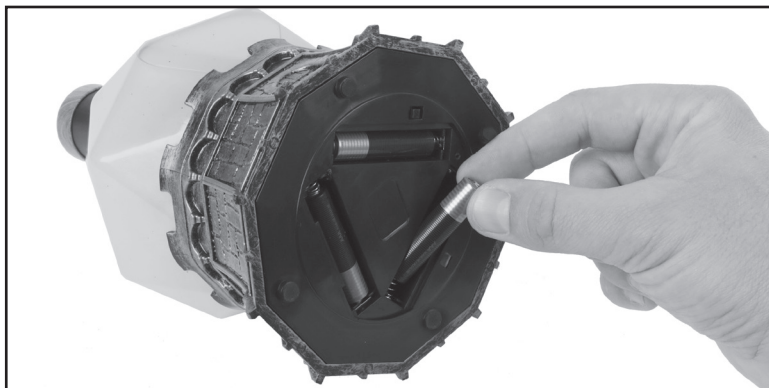

Inserte 3 pilas AAA (no incluidas).

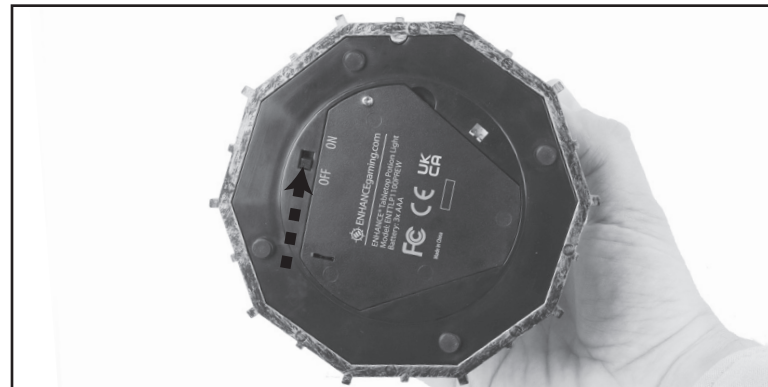

Vuelva a colocar la tapa de la batería y mueva el interruptor de encendido a la posición ON.

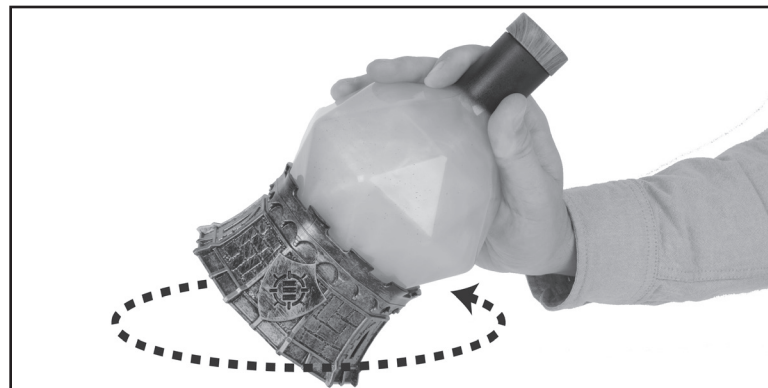

NOTA: Si la poción no gira. Apague la luz, agítela suavemente y luego vuelva a encenderla.

Bedienungsanleitung



Schrauben Sie das Batteriefach ab (Schraubendreher nicht im Lieferumfang enthalten).

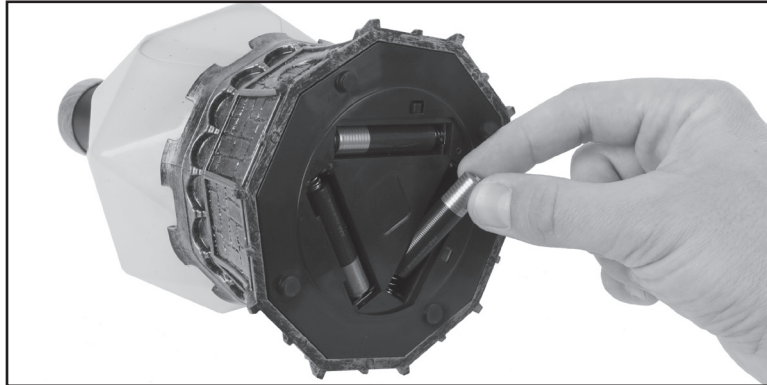

Legen Sie 3x AAA-Batterien ein (nicht im Lieferumfang enthalten).

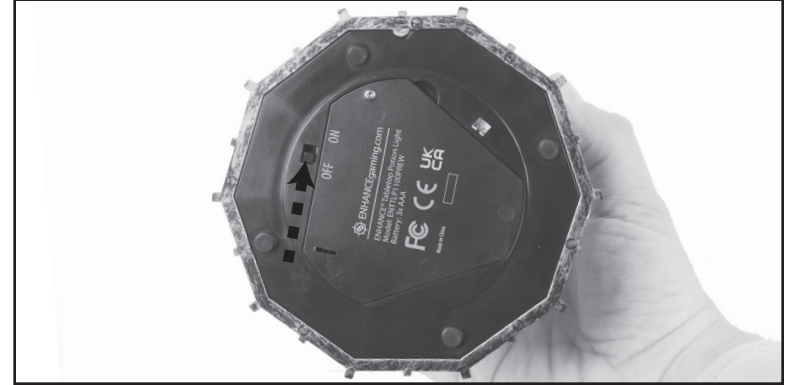

Bringen Sie die Batterieabdeckung wieder an und stellen Sie den Netzschalter auf die Position ON.

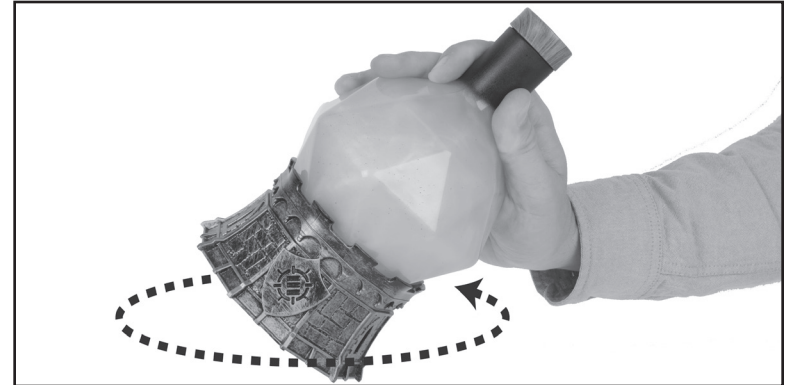

HINWEIS: Wenn der Trank nicht wirbelt. Schalten Sie das Licht aus, schütteln Sie es leicht und schalten Sie es dann wieder ein.

Istruzioni per l'uso



Svitare lo sportello della batteria (cacciavite non incluso).

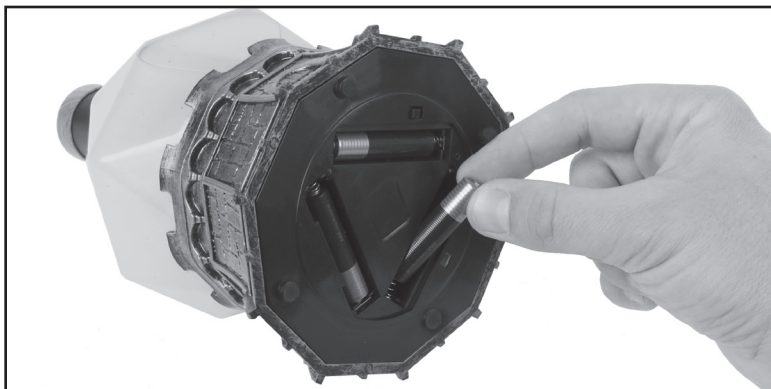

Inserire 3 batterie AAA (non incluse).



Riposizionare il coperchio della batteria e spostare l'interruttore di alimentazione in posizione ON.

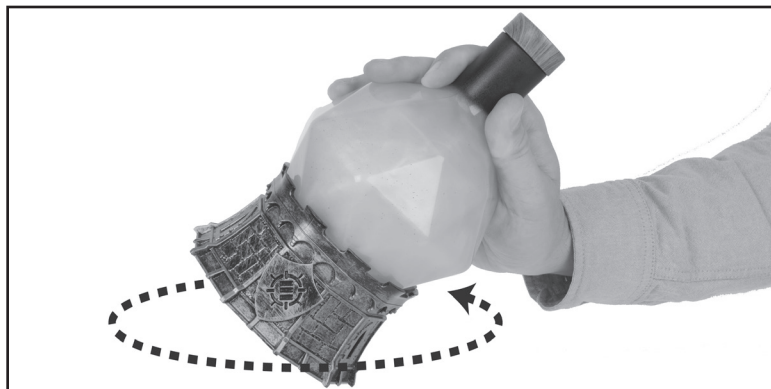

NOTA: se la pozione non è vorticoso. Spegni la luce, scuotila leggermente e poi riaccendila.



拧开电池盖（不含螺丝刀）。

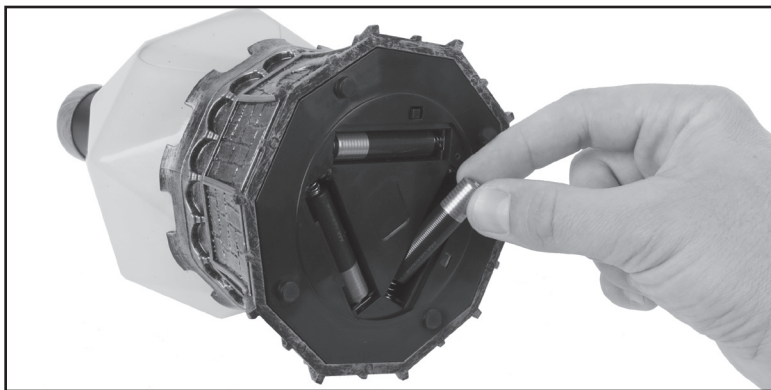

插入 3 节 AAA 电池（不包含在供货范围内）。

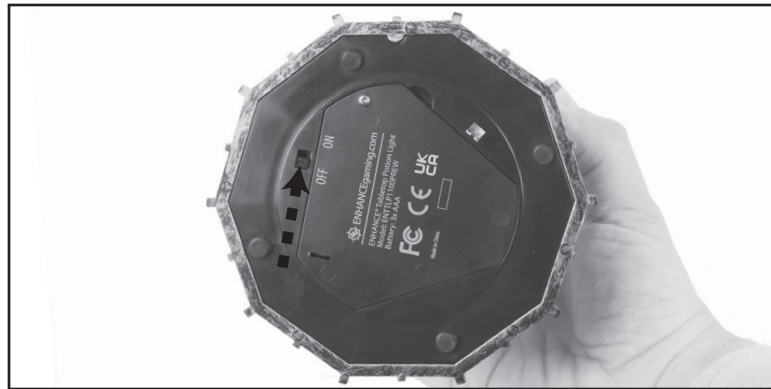

装回电池盖并将电源开关移至 ON 位置。

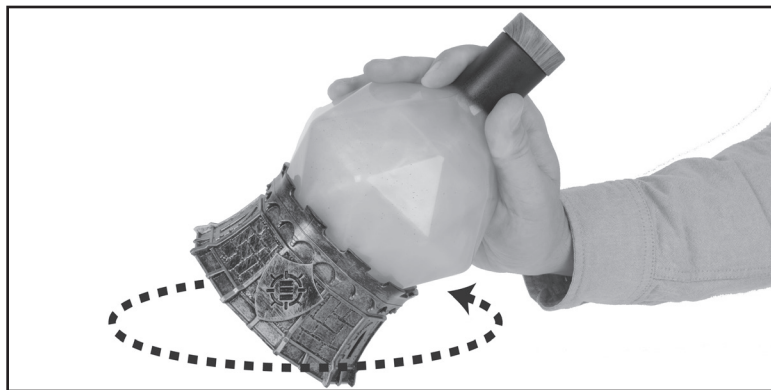

注意：如果药水没有旋转。关掉灯，轻轻摇晃一下，然后重新打开。



Product specifications
Spécifications du produit
Especificaciones del producto
Produktspezifikationen
Specifiche del prodotto
产品规格

Battery: 3x AAA (not included)

Battery life: Up to 17 hours

Dimensions: 8.46 x 6.49 x 6.49 inches

Weight: 2.68 pounds

Batterie: 3x AAA (non incluses)

Autonomie de la batterie: jusqu'à 17 heures

Dimensions: 21.5 x 12.6 x 12.6 cm

Poids: 1.22kg



FCC Compliance Notice

This device complies with Part 15 of the FCC Rules. Operation is subject to the following two conditions: 1) this device may not cause harmful interference, and 2) this device must accept any interference received, including interference that may cause undesired operation. Compliance Information Statements: This equipment has been tested and found to comply with the limits for a Class B digital device, pursuant to Part 15 of the FCC Rules. These limits are designed to provide reasonable protection against harmful interference in a residential installation. This equipment generates uses and can radiate radio frequency energy and, if not installed and used in accordance with the instructions, may cause harmful interference to radio communications. However, there is no guarantee that interference will not occur in a particular installation. If this equipment does cause harmful interference to radio or television reception, which can be determined by turning the equipment off and on, the user is encouraged to try to correct the interference by one or more of the following measures: 1) reorient or relocate the receiving antenna; 2) increase the separation between the equipment and receiver; 3) connect the equipment into an outlet on a circuit different from that to which the receiver is connected; 4) consult the dealer or an experienced radio/TV technician for help. Modifications to this product not authorized by Accessory Power could void your right to use or operate this product by the FCC. Where shielded interface cables or accessories have been provided with the product or specified additional components or accessories elsewhere defined to be used with the installation of the product, they must be used in order to ensure compliance with FCC regulations.

WARRANTY GARANTIE GARANTÍA



GARANTIE GARANZIA 保固

This product comes with a 1 year limited warranty, the acceptance of which is a condition of sale. Register this product within 30 days of sale to activate a complimentary 2 year warranty extension and receive free advanced technical support. For warranty program details, registration, and support visit ENHANCEgaming.com/warranty

Ce produit à une garantie limitée de 1 an, la condition étant son achat. Enregistrer ce produit dans les 30 jours suivant son achat pour activer l'extension de garantie de 2 ans et bénéficier de notre service après-vente gratuit. Pour en savoir plus sur l'enregistrement et le service après-vente allez sur ENHANCEgaming.com/warranty

Este producto viene con una garantía limitada de 1 año, la aceptación de que es una condición de la venta. Registrar este producto dentro de los 30 días de la venta para activar una extensión de cortesía 2 años de garantía y recibir soporte técnico avanzado libre. Para los detalles del programa de garantía, el registro, y una visita de apoyo ENHANCEgaming.com/warranty

Dieses Produkt kommt mit einer 1-Jahres-Garantie, deren Annahme ist eine Bedingung des Verkaufs. Registrieren Sie dieses Produkt innerhalb von 30 Tagen den Verkauf an ein kostenloses 2 Jahre Garantie-Erweiterung zu aktivieren und erhalten kostenlose erweiterte technische Unterstützung. Für Garantie-Programm Details, Registrierung und Support Besuch ENHANCEgaming.com/warranty

Questo prodotto viene fornito con una garanzia limitata di 1 anno, la cui accettazione è una condizione di vendita. Registra questo prodotto entro 30 giorni di vendita per attivare tutte le mattine una estensione di garanzia di 2 anni e di ricevere supporto tecnico avanzato gratuito. Per i dettagli del programma di garanzia, la registrazione e supporto visitare ENHANCEgaming.com/warranty

本产品带有1年有限保修的销售承诺，在购买后30天内注册本产品将获赠2年延长保修及得到免费高级技术支持，关于保修流程的细节、注册和支持，请访问 ENHANCEgaming.com/warranty

© 2023 AP Global, Inc. All rights reserved. Accessory Power, the Accessory Power logo, ENHANCE, the ENHANCE logo and other marks and logos are either registered trademarks or trademarks of AP Global, Inc. in the United States and/or other countries. All other trademarks are the property of their respective owners.

Manufactured in China. Designed in California.

© 2023 AP Global, Inc. Tous droits réservés. Accessory Power, le logo Accessory Power, ENHANCE, le logo ENHANCE et les autres marques et logos sont des marques déposées ou des marques de AP Global, Inc. aux États-Unis et/ou dans d'autres pays. Toutes les autres marques sont la propriété de leurs propriétaires respectifs.

Fabriqu  en Chine. Con u en Californie.

ENHANCEgaming.com/recycle



 ENHANCEgaming

 ENHANCEbrand

 @ENHANCEgaming

 ENHANCE

Potion Light

PURPLE MODEL: ENTTLP1100PREW
GREEN MODEL: ENTTLP1100GNEW